

HEAT KING

GROUND THAWING & CONCRETE CURING REFERENCE GUIDE

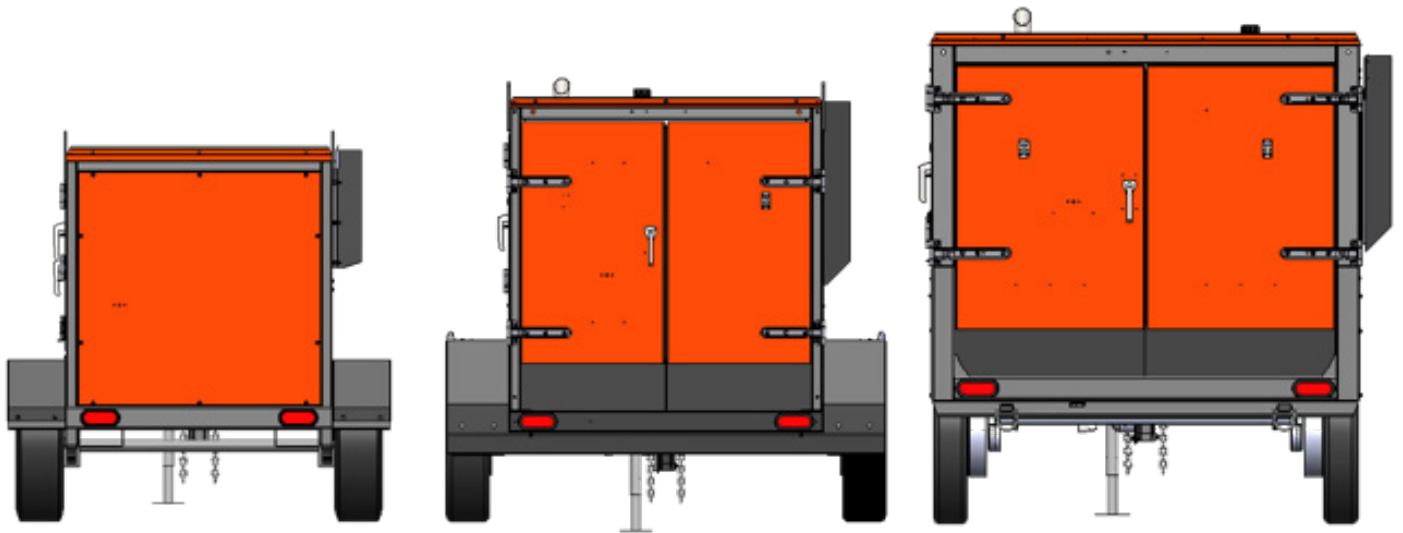

WWW.HEAT-KING.CA

TABLE OF CONTENTS

Principles of Ground Thawing	2
Ground Thawing Illustration	3
Principles of Concrete Curing	5
Slab on Grade Illustration 1 Temperature Above 25°F- Hose Reused	6
Slab on Grade Hose Illustration 2 Temperature Below 25°F - Hose Abandoned	7
Grade Beams & Walls (up to 10") Illustration Temperature Below 10°F - Hose Abandoned	8
Grade Beams & Walls (10-24") Illustration 1 Temperature Above 10°F - Hose Reused	9
Grade Beams & Walls (10 - 24") Illustration 2 Temperature Below 10°F - Hose Abandoned	10



Principles of Ground Thawing

The Soil

Soil particles do not freeze, it is the moisture around the particles that freezes. Think about a bucket of pea gravel. If it is dry, it can be at -40°F and it is still as easy to move the stones around as if it were +70°F. Now fill the bucket with water to the top of the gravel and let it freeze. Now the whole thing is as hard as a rock!

When we are thawing ground, we are thawing the water around the soil particles.

It takes a lot of energy to change snow or ice to liquid water.

If there is any snow or ice on the thaw site, remove it mechanically. It is far more efficient than trying to melt it with the Heat King. Save all of the energy for thawing the ground, not melting surface ice and snow.

Frozen ground is a great barrier for water flow.

Complete the Thaw. If you do not let the ground thaw all of the way down, the water that has melted will have no where to go, so it will stay on the surface. Once the frost has been fully removed, the water will drain back down to the water table, and the site will not be as muddy.



Heat Transfer

Water in its liquid form is a great conductor of heat. It is much better than air.

Think about the air in a warm oven. You can put your hands in a warm oven to get out a plate of food, even if the oven is at 200°F. If you put your hands in water that is at 200°F even for a couple of seconds you will scald yourself.

The Heat King uses this 2 ways, first to transfer heat from heater to the ground, and then to transfer heat from the surface to the lower levels of ground.

Heat does not necessarily rise, it moves from warm things to cold things.

Sit on a steel bench in your underwear in winter and you will never forget this fact! The steel is cold, you are warm, the heat goes from you to the bench, even though the bench is below you. Hot air rises because it is lighter than cold air, and this is why some people think heat always rises.

It takes a lot of heat energy to change water from liquid to vapor.

If this water vapor escapes, it takes all of that heat with it. Rather than let it vent, convert the vapor into water so that it can go back down into the ground and continue the thawing process. When ground thawing, ALWAYS use a vapor barrier. Don't let anyone tell you that because the insulating blankets have poly covering that they are good enough. They probably are not. Few things will slow a thaw more than if water vapor is venting. Another nice benefit is if you put the vapor barrier down before the hoses, it will keep the hoses much cleaner when the thaw is complete.

GROUND THAWING

HEAT KING THAW PLAN

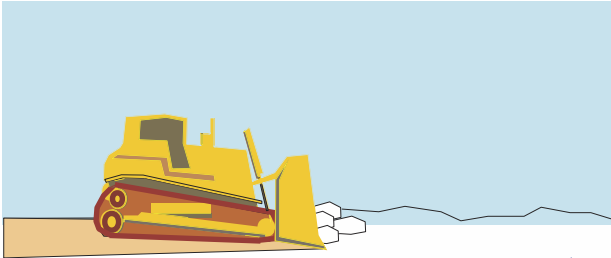

FROST

- ▶ Remove all the surface ice and snow from the site
- ▶ Determine the depth of the frost

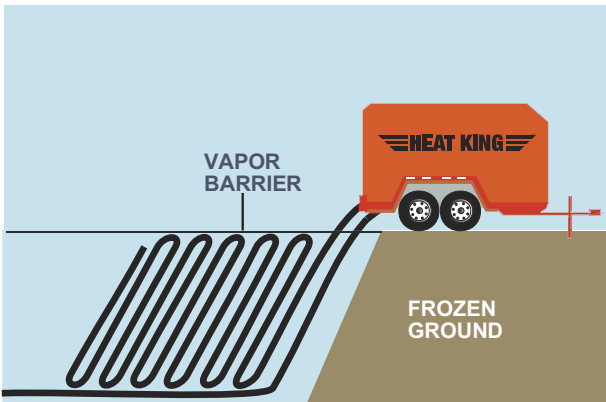

- ▶ Place a polyethylene vapor barrier over the frozen ground. Failure to do so will dramatically lengthen the time required to complete the thaw.
- ▶ Place hoses on the area to be heated. Spacing of the hoses is determined by the frost depth. Generally, use all of the hose on the reel, even if it is not needed. This will speed the thaw.
- ▶ Preheat the Heat King to 180° F.

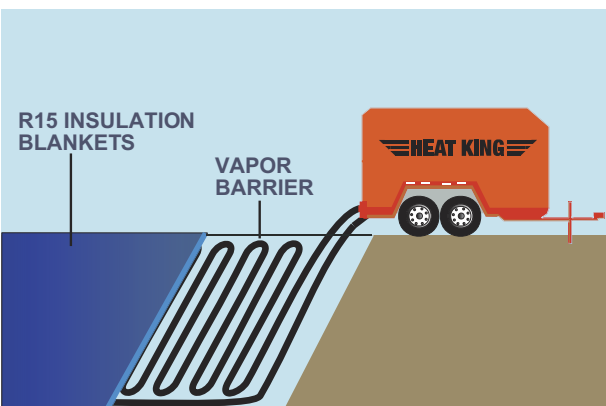

- ▶ Place insulation blankets over the hoses. Blankets should be poly clad. The more blankets the better, but they should provide an R factor of R15. If it is above 25°F and there is less than 2 feet of frost R10 is recommended.

Start the thaw. do not stop until all of the frost is removed or the water will not be able to drain down to the water table.

GROUND THAWING

HEAT KING THAW PLAN

HOSE LAYOUT

FROST DEPTH	HOSE SPACING
1' - 3'	24" apart
4'	16" apart
5'+	14" apart

With this configuration and ideal soil conditions you can expect a thaw of 1' per day for the first 3' and 1/2' per day to 6'. Some overriding factors which slow the rate of thaw are:

▶ **Soil Compaction**

If the area to be thawed is compacted the rate of thaw may slow to 1/2' per day or less.

▶ **Soil Moisture**

If the moisture content in the soil is low as in the case of dry clay, the rate will slow to 1/2' per day. The same is true for soil where the moisture content is very high. As in the case of saturated silt, the rate of thaw may slow to 1/2' per day or less.

▶ **Outdoor Temperatures**

The outdoor temperature can also effect the rate of thaw. If there are high winds and the temperature is at or below -30° F, add hay bales on top of the blankets for further insulation.

These are general guidelines to follow for optimum performance of the Heat King under typical operating conditions. Extreme soil or weather conditions may call for different configurations. Extreme soil conditions may call for different configurations. Call Tamarack Industries if you need further help with your thaw plan. Always have your structural or civil engineer approve your plan.

Principles of Concrete Curing

Concrete does not dry; it cures. This is a chemical reaction that puts out heat, especially during the first day. The warmer the concrete the faster it cures. When it is frozen or is very cold, it stops curing altogether.

Concrete goes through several stages during it's use.

- It comes to the site in a liquid or plastic form when it can be placed, consolidated, screeded and bull floated.
- After an initial set (6-8 hours at 60 - 70°F) it can be finished through floating, and troweling or brooming.
- Final set is usually another 6 hours at 70°F. It is now, hard, but far from fully cured. It continues to cure and gain strength as time goes on so long as it is warm enough.
- After 6 or 7 days at 65-70°F concrete has generally achieved 75% of its design strength. At this point forms can be stripped and loads applied.
- After 28 days concrete has achieved its design strength, although, it will continue to cure and gain strength for up to a year.

Conditions needed for a good cure

Moisture

- The concrete curing process uses up water, therefore it must have moisture to continue curing. If concrete gets too hot, the moisture will evaporate and it will stop curing.
- This is why we don't run the Heat King at 180°F during curing.

A temperature of 65-80°F

- The lower the temperature, the slower the cure. This wastes time on the project. There is also a risk of freezing. If concrete freezes before the final set (about 12 hours at 70°F) it may have to be removed. If concrete freezes after the initial set, it will stop curing.
- With the Heat King you can protect the concrete from freezing, and maintain the correct temperature to keep the concrete curing.

Goals of Concrete Curing

The goals in concrete curing in cold conditions are:

- Don't let the concrete freeze
- Keep the concrete above 65°F so that it cures properly and quickly
- Keep the concrete below 80°F so that it won't bake and loose moisture

CONCRETE CURING

SLAB ON GRADE ABOVE 25°F (HOSE IS RE-USED)

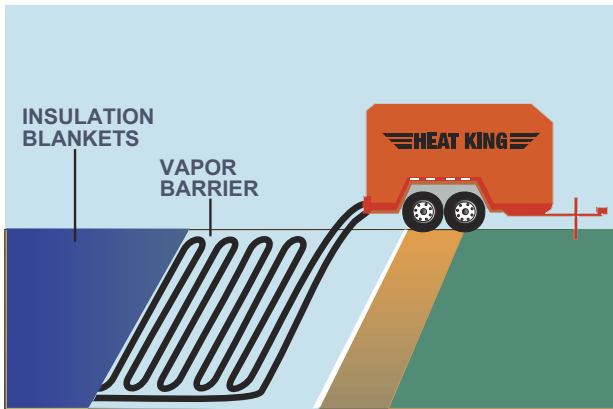

- ▶ Thaw the ground according to the Heat King Thaw plan
- ▶ Prepare the ground for concrete
- ▶ Place Rebar
- ▶ Preheat the ground, run Heat King at 180°F, place hoses at 24" centers, to put on insulating blankets and let the ground heat to at least 85°F

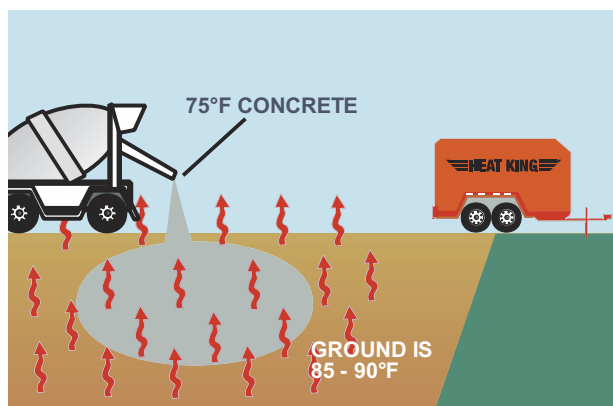

- ▶ Remove insulating blankets and rewind the hoses
- ▶ Turn the Heat King down to 85°F
- ▶ Bring in the concrete at 75°F Place 75°F concrete

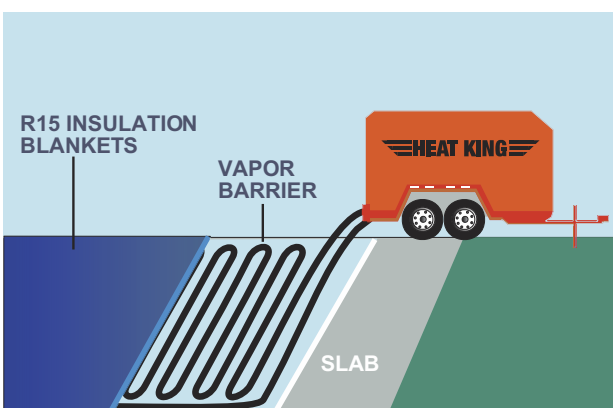

- ▶ As soon as the concrete has reached the final set put on a vapor barrier
- ▶ Place hoses, if you have extra hose use it. the more hose that you use, the more even the heat
- ▶ Place R15 of insulating blankets
- ▶ Monitor the return temperature on the Heat King.
- ▶ Adjust the Heat King until the Return temperature is in the 65 - 75°F range
- ▶ Keep the heat on until the desired design strength has been achieved (this will not be less than 7 days)
- ▶ This is a general guideline, have your structural or civil engineer approve your plan.

CONCRETE CURING

SLAB ON GRADE BELOW 25° F (HOSE ABANDONED)

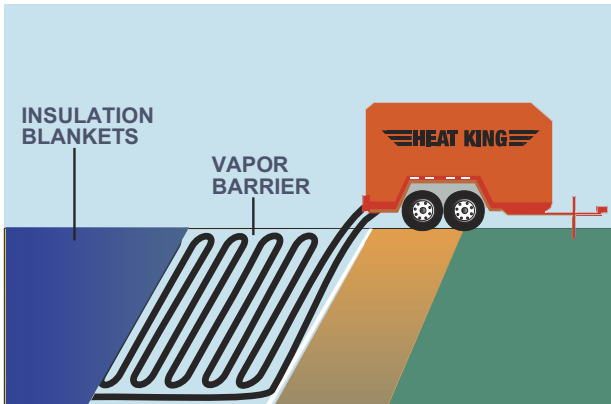

- ▶ Thaw the ground according to the Heat King Thaw plan
- ▶ Prepare the ground for concrete
- ▶ Place hoses at 20" Centers
- ▶ Start preheating the ground, run Heat King at 180°F
- ▶ Place rebar above hose
- ▶ Put on insulating blankets and let the ground heat to at least 85°F

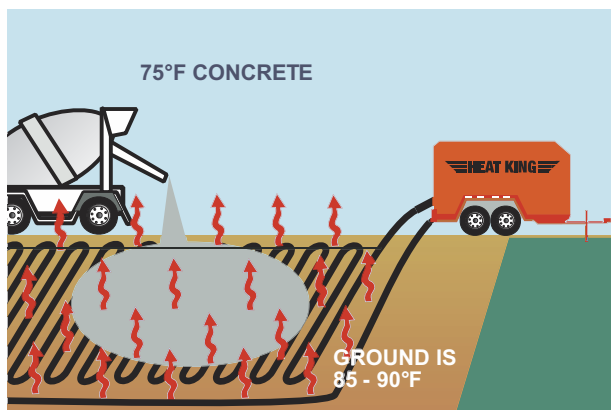

- ▶ Remove insulating blankets and rewind the hoses
- ▶ Turn the Heat King down to 85°F
- ▶ Bring in the concrete at 75°F.
- ▶ Place 75°F concrete on top of hoses

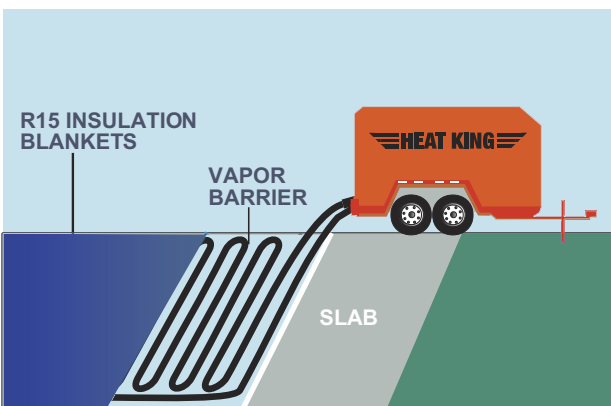

- ▶ As soon as the concrete has reached the final set put on a vapor barrier and R 15 insulating blankets
- ▶ Monitor the return temperature on the Heat King. Adjust the Heat King until the return temperature is in the 65 - 75°F range
- ▶ Keep the heat on until the desired design strength has been achieved (this will not be less than 7 days)
- ▶ You can now use the system as a temporary radiant floor heating system until the permanent heating system is in place. Do not run the Heat King above 85°F until the concrete is fully cured
- ▶ This is a general guideline, have your structural or civil engineer approve your plan.

CONCRETE CURING

GRADE BEAMS AND WALLS BELOW 10°F (HOSE ABANDONED)

WALLS UP TO 10" THICK

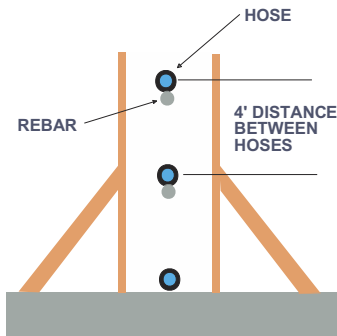

- ▶ Run hose at bottom of wall in the middle of the forms
- ▶ Run another hose through the wall for every 4' of height or portion thereof
- ▶ Run a hose near the top of the wall

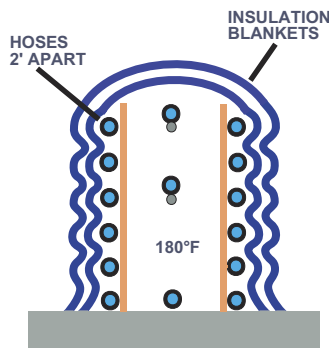

- ▶ Run hoses on outsides of form at bottom, and every 2' up the forms (both sides)
- ▶ Put at least R 15 of insulating blankets over forms
- ▶ Run the Heat King at 180°F to preheat forms and rebar for at least 3 hours

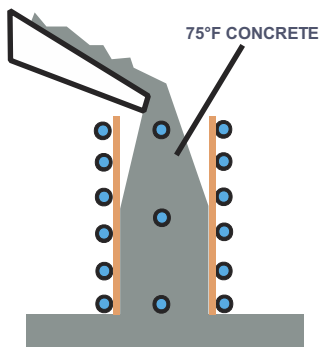

- ▶ Remove the insulating blankets
- ▶ Turn the Heat King down to 85°F
- ▶ Pour 75°F concrete

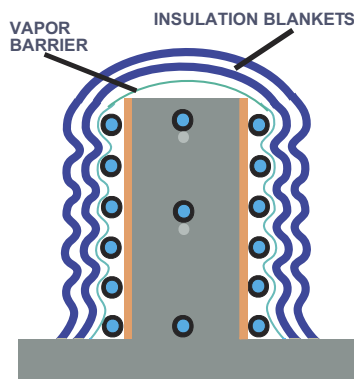

- ▶ Replace vapor barrier, insulating blankets and wrap tight
- ▶ Monitor the return temperature on the Heat King
- ▶ Adjust the Heat King until the return temperature is in the 65 - 75°F range
- ▶ Keep the heat on until the desired design strength has been achieved. (This will not be less than 7 days)
- ▶ This is a general guideline, have your structural or civil engineer approve your plan

CONCRETE CURING

GRADE BEAMS AND WALLS ABOVE 10°F (HOSE IS RE-USED)

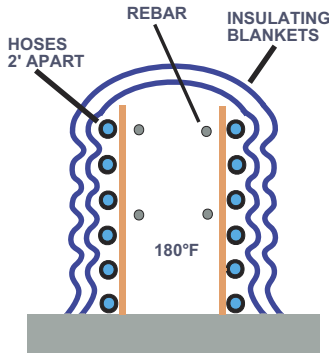

- ▶ Run hoses on outsides of form at bottom, and every 2' up the forms (both sides)
- ▶ Put at least R 15 of insulating blankets over forms
- ▶ Run the Heat King at 180°F to preheat forms and rebar for at least 3 hours

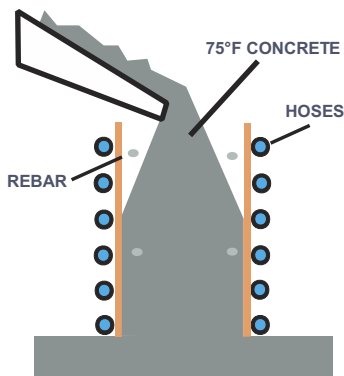

- ▶ Remove the insulating blankets
- ▶ Turn the Heat King down to 100°F
- ▶ Pour 75°F concrete

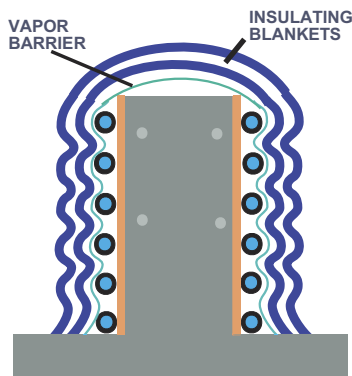

- ▶ Cover the forms with a vapor barrier, insulating blankets and wrap tight. It is important that there is an air tight, well insulated envelope around the forms
- ▶ Monitor the return temperature on the Heat King
- ▶ Adjust the Heat King until the return temperature is in the 65 - 75°F range
- ▶ Keep the heat on until the desired design strength has been achieved. (This will not be less than 7 days)
- ▶ This is a general guideline, have your structural or civil engineer approve your plan

CONCRETE CURING

GRADE BEAMS AND WALLS BELOW 10°F (HOSE ABANDONED)

WALLS UP TO 10" THICK

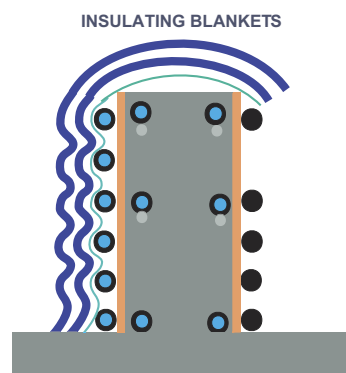
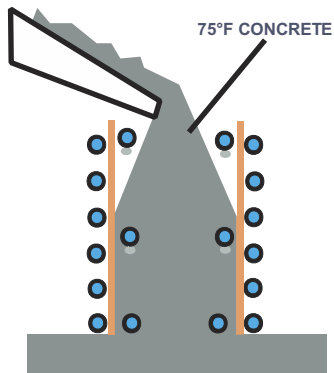
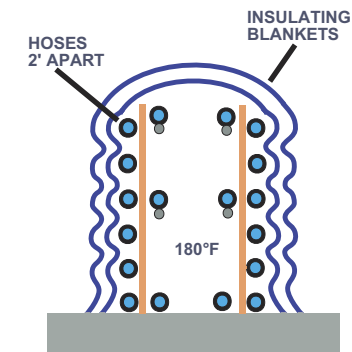
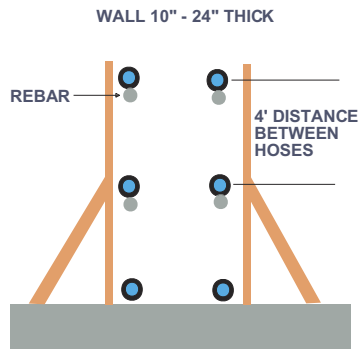

- ▶ Run 2 hoses at bottom of wall in forms within 2" of form
- ▶ Run another 2 hoses through the wall for every 4' of height or portion thereof
- ▶ Run 2 hoses near the top of the wall within 2" of form

- ▶ Run hoses on outsides of form at bottom, and every 2' up the forms (both sides)
- ▶ Put at least R 15 of insulating blankets over forms
- ▶ Run the Heat King at 180°F to preheat forms and rebar for at least 3 hours

- ▶ Remove the insulating blankets
- ▶ Turn the Heat King down to 85°F
- ▶ Pour 75°F concrete

- ▶ Replace vapor barrier, insulating blankets and wrap tight
- ▶ Monitor the return temperature on the Heat King
- ▶ Adjust the Heat King until the return temperature is in the 65 - 75°F range
- ▶ Keep the heat on until the desired design strength has been achieved. (This will not be less than 7 days)
- ▶ This is a general guideline, have your structural or civil engineer approve your plan

HEAT KING



Tamarack
Industries

**1205 SHERWIN RD
WINNIPEG, MB CANADA
R3H 0V1**

TOLL-FREE 800.661.0304

PHONE 204.885.5800

FAX 204.885.7557

WWW.HEAT-KING.CA